



Super-4-CCA Fatwire™ Installation Manual

PerihelionDesign.com

About Super-4-CCA Fatwire:

Specifications:

Weight of the insulated wire is 1.72 ounces/foot.

Stranding is 7X20X23g

Diameter with insulation is 0.435"

Bend radius—about 3/4 inch. Very flexible and easy to handle.

Insulation material: Custom polyvinyl TPE proprietary

Flame retardant, 105 °C, fuel proof, oil proof, cut resistant, low smoke, non-cracking at low temperature.

Resistance—0.244 milliohms/foot

Current carrying ability 157A continuous.

Recommended connectors: AMP Solistrand™, Tin plated copper per MIL -T-10727.

UL/CSA/MIL 170 °C

Super-4-CCA (Copper Clad Aluminum) is a custom-made wire specially designed for experimental aircraft battery-starter wire and ground conductor bus applications. Nominally it has the characteristics of AWG 4 copper wire, but is much lighter in weight, and lower resistance.

Although aluminum conductors have had a problematic history in electrical service, especially for low voltage, copper-clad aluminum has had no such problems at all.

Installation Instructions:

It is suggested that the following procedure be used to make a good termination for the wire, using Tyco AMP No. 320383 (1/4" hole) crimp lugs. Alternatively there are many wire connectors available at your local electrical contractor's supply house that you may wish to explore.



Remove 3/4" of the insulation from the end. Make sure you do not nick the metal strands.



Crimping the Lugs:

Check to make sure the lugs slide onto the bare wire end. Slip on heat shrink tubes as desired. (5/8" clear is best but any color is fine).

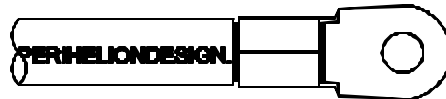

If you do not have a suitable tool for crimping the lug onto the wire end, (the professional tools are usually very expensive) you can make a handy jig to do this—

Take two pieces of metal. Clamp them together and drill a 17/32" diameter hole through the block, and a 5/16" clearance hole perpendicular to the first hole to accept a 5/16" steel punch with a rounded face ground onto the end.

Clamp the wire and the lug into the jig in the jaws of a sturdy vice, leaving a 1/8" gap between the insulation and the lug. Hammer the punch firmly until the wire shows no movement in the lug.

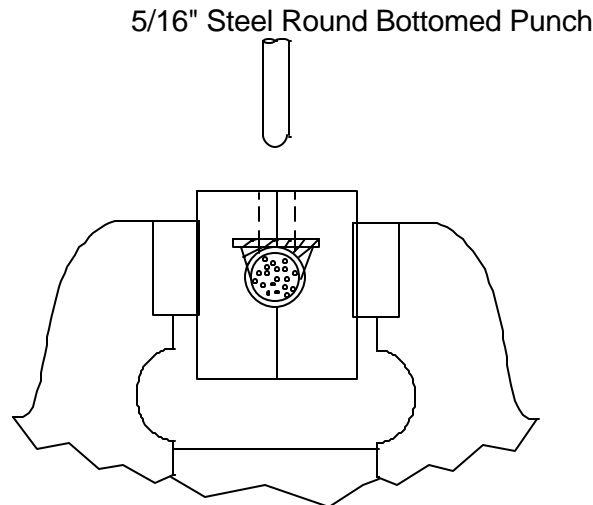

The crimped lug should look more or less like this:

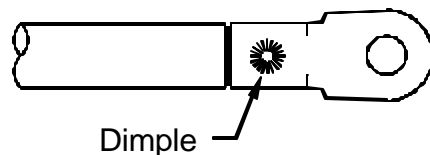

Soldering the lugs---

Fixture the crimped connectors to a piece of wood using a wood screw or drywall screw, with the flat side of the lug down. Now drag out that big old 100W soldering iron (everyone has one—or you can use the soldering tip for your propane torch—but NOT the flame), wire brush the crud off the end, crank it up and heat the lug and copper clad aluminum conductor. Using heavy-gauge rosin core electrical solder, fill the interstices with solder until the solder comes out the back end (you should see it in the little 1/8" gap). With reasonable care the wire insulation will not be damaged.

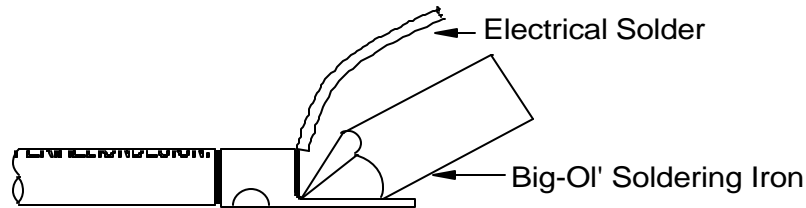

Rinse off the rosin flux with some tri-chlor or MEK. We suggest some type of electrical coating be used to seal the small 1/8" gap and the exposed face of the wire to make a neat job. Epoxy or silicone would do. Fingernail polish would be great.

Shrink heat shrink tubing.

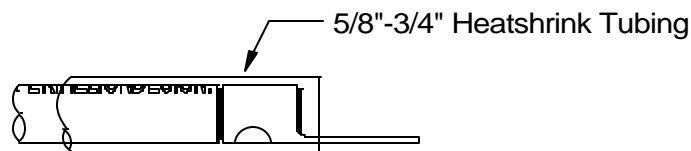

Done.

The installation of any large wire follows the same basic rules used when installing hoses and tubing—prevent motion at the joint by good design, adequate service loops and proper installation.

Eric M. Jones

Perihelion Design
24Sept05